

60 Frame Piston Pump

Models

6020 6040

FEATURES

Superior Design

- Triplex Uniflow design provides continuous forward fluid flow for smooth operation.
- Wetted cups and floating pistons are lubricated and cooled by pumped fluid for long cup life.
- Mechanically actuated inlet valves give strong lift and easy prime.
- 304 stainless steel discharge valves for wear resistance.
- Oil bath crankcase assures optimum lubrication.
- 100% wetted seal design allows pumped fluid to cool and lubricate for longer life.

Quality Materials

- Cylinder and sleeve wear surfaces are hard chrome plated 304 stainless steel for maximum durability and abrasion resistance.
- Chrome plated, brass manifolds and optional stainless steel manifolds are strong and corrosion resistant.
- Chrome-moly crankshaft gives unmatched strength and surface hardness.
- Oversized crankshaft bearings with greater loading capacity mean longer bearing life.
- Die cast aluminum crankcase provides high strength, minimum weight and precision tolerance control.

Easy Maintenance

- Stepped stainless steel piston rod with chrome-plated, stainless steel sleeve allows easy replacement from front of pump.
- All wet-end wear parts are easily serviced without entering crankcase, requiring less time and effort.
- Wear parts are available in convenient kits.
- Routine lubrication checks are the only maintenance required on this precision built pump.

$$\frac{\text{DETERMINING THE PUMP R.P.M.}}{\text{Rated G.P.M.}} = \frac{\text{“Desired” G.P.M.}}{\text{Rated R.P.M.}}$$

$$\frac{\text{DETERMINING THE REQUIRED H.P.}}{\text{GPM} \times \text{PSI}} = \frac{\text{Electric Brake H. P. Required}}{1460}$$

$$\frac{\text{DETERMINING MOTOR PULLEY SIZE}}{\text{Motor Pulley O.D.}} = \frac{\text{Pump Pulley O.D.}}{\text{Motor R.P.M.}}$$

Note: Consult engine manufacturer when using gas or diesel engine. Refer to pump Service Manual for important Inlet Condition Check-List, Start-up Procedure, Tech Bulletins and Pump Maintenance information.

SPECIFICATIONS

MODEL 6020

	U.S. Measure	Metric Measure
Volume	60 GPM	(227 L/M)
Discharge Pressure	100 to 1000 PSI	(7 to 70 BAR)
Bore.....	2.205"	(56 mm)

MODEL 6040

	U.S. Measure	Metric Measure
Volume	40 GPM	(151 L/M)
Discharge Pressure	100 to 1500 PSI	(7 to 105 BAR)
Bore.....	1.811"	(46 mm)

COMMON SPECIFICATIONS

RPM	500 RPM	(500 RPM)
Stroke.....	2.461"	(62.5 mm)
Crankcase Capacity.....	10 Qts.	(9.46 L)
Maximum Fluid Temperature	160°F	(71°C)
Max. Inlet Pressure	-8.5 to +40 PSI	(-0.6 to +2.8 BAR)
Inlet Ports (1)	2" NPT	(2" NPT)
Discharge Ports (3).....	1-1/4" NPT	(1-1/4" NPT)
Pulley Mounting	Either Side	(Either Side)
Shaft Diameter	1.772"	(45 mm)
Weight.....	235 lbs.	(107 kg)
Dimensions.....	31.4x24.0x17.1"	(797x610x434 mm)

HORSEPOWER REQUIREMENTS

MODEL	FLOW		PRESSURE				RPM	DRIVE
			PSI 800	PSI 1000	PSI 1200	PSI 1500		
	U.S. GPM	L/M	BAR 55	BAR 70	BAR 85	BAR 105		
6020	60	227	32.9	41.2	N/A	N/A	500	Consult CAT PUMPS for Pump & Motor Pulley sizes
	50	189	27.4	34.3	N/A	N/A	417	
	40	151	22.0	27.4	N/A	N/A	333	
6040	40	151	22.0	27.4	32.9	41.2	500	Consult CAT PUMPS for Pump & Motor Pulley sizes
	36	136	19.8	24.7	29.7	37.0	478	
	30	114	16.5	20.6	24.7	30.9	375	

See complete Drive Packages [Incls: Pulleys, Belts, Hubs, Key] Tech Bulletin 03.

“Customer confidence is our greatest asset”

PARTS LIST

ITEM	PART NUMBER		DESCRIPTION	QTY
	6020 MATL	6040 MATL		
● 2	43048	43048	Key (M14x9x90)	1 ●
5	80296	80296	Screw, HH (M10x40)	8
6	12503	12503	Lockwasher, Split (M10)	8
7	12490	12490	Washer, Flat (M10)	8
8	29443	29443	Case, Bearing, Outer	2
10	29444	29444	O-Ring, Bearing Case	2
11	11443	11443	Oil Seal, Crankshaft	2
15	29441	29441	Bearing, Roller	2
16	29442	29442	Case, Bearing, Inner	2
17	29444	29444	O-Ring, Bearing Case	2
20	115983	115983	Rod, Connecting Assy	3
21	44941	44941	Washer Tab	3
22	43641	43641	Washer, Shim, Con-Rod Cap	6
25	29440	29440	Crankshaft	1
31	828710	828710	Protector, Oil Cap	1
32	43211	43211	Cap, Oil Filler	1
33	14177	14177	O-Ring, Cap	1
34	44319	44319	Bolt, Eye	1
38	11338	11338	O-Ring, Dipstick	1
39	27769	27769	Dipstick	1
40	80288	80288	Screw, Hex Cap (M10x30)	8
41	12503	12503	Lockwasher, Split	8
42	12490	12490	Washer, Flat (10mm)	8
48	25625	25625	Plug, Drain (1/4x11)	1
49	23170	23170	O-Ring, Drain Plug	1
50	29438	29438	Cover, Crankcase	1
51	29439	29439	Gasket, Crankcase Cover	1
● 53	43284	43284	Crankcase	1 ●
55	85449	85449	Stud (M16x45)	4
56	29457	29457	Pan, Oil	1
64	29481	29481	Pin, Piston Rod	3
65	43809	43809	Rod, Piston	3
69	29453	29453	Washer, Oil Seal	3
70	29454	29454	Oil Seal, Crankcase	3
75	29340	29340	Barrier Slinger	3
77	13967	13967	O-Ring, Sleeve	6
	14308	14308	O-Ring, Sleeve	6
80	43129	43129	Sleeve (M25)	3
	43271	43271	Sleeve (M25)	3
81	29455	29455	Back-up-Ring, Sleeve	3
100	29456	29456	Seal Retainer	3
101	43136	43136	Wick, Oil (M25)	3
106	43130	43130	LPS, Seal (M25)	3
	43132	43132	LPS, Seal (M25)	3
110	43283	43283	Manifold, Inlet	1
● 117	29805	29805	Manifold, Inlet	1 ●
117	88902	88902	Stud (M16x277)	4
119	29460	43200	Valve, Inlet	3
133	29461	43201	Piston Assembly	3
	30609	30837	Piston Assembly w/O-Ring	3
	30646	—	Piston Assembly w/O-Ring	3
135	29463	29463	Spacer, Piston	3
136	29464	43203	Retainer, Piston	3
137	44272	44272	Washer, Conical (M14x22)	3
138	29465	29465	Nut, Slotted (M14)	3
139	29354	29354	Cotterpin (M2.5x25)	3
143	12392	12392	O-Ring, Cylinder	6
	13279	13279	O-Ring, Cylinder	6
150	29466	43204	Cylinder	3
	43279	43392	Cylinder	3
153	23116	23116	Back-up-Ring, Cylinder	3
162	43206	43206	Back-up-Ring, Seat	3
163	29471	29471	O-Ring, Seat	3
	29479	29479	O-Ring, Seat	3
164	43205	43205	Seat	3
166	29468	29468	Valve	3
167	29469	29469	Spring, Valve	3
168	43143	43143	Retainer, Spring	3
185	29472	29472	Manifold, Discharge	1
● 186	29806	29806	Manifold, Discharge	1 ●
186	12504	12504	Lockwasher (M16)	8
187	29473	29473	Bolt, Discharge Manifold (M16x225)	4
194	88853	88853	Nut, Hex (M16)	8
196	29476	29476	Plug (1-1/4" NPT)	1
197	22187	22187	Plug (3/8" NPT)	1

EXPLODED VIEW

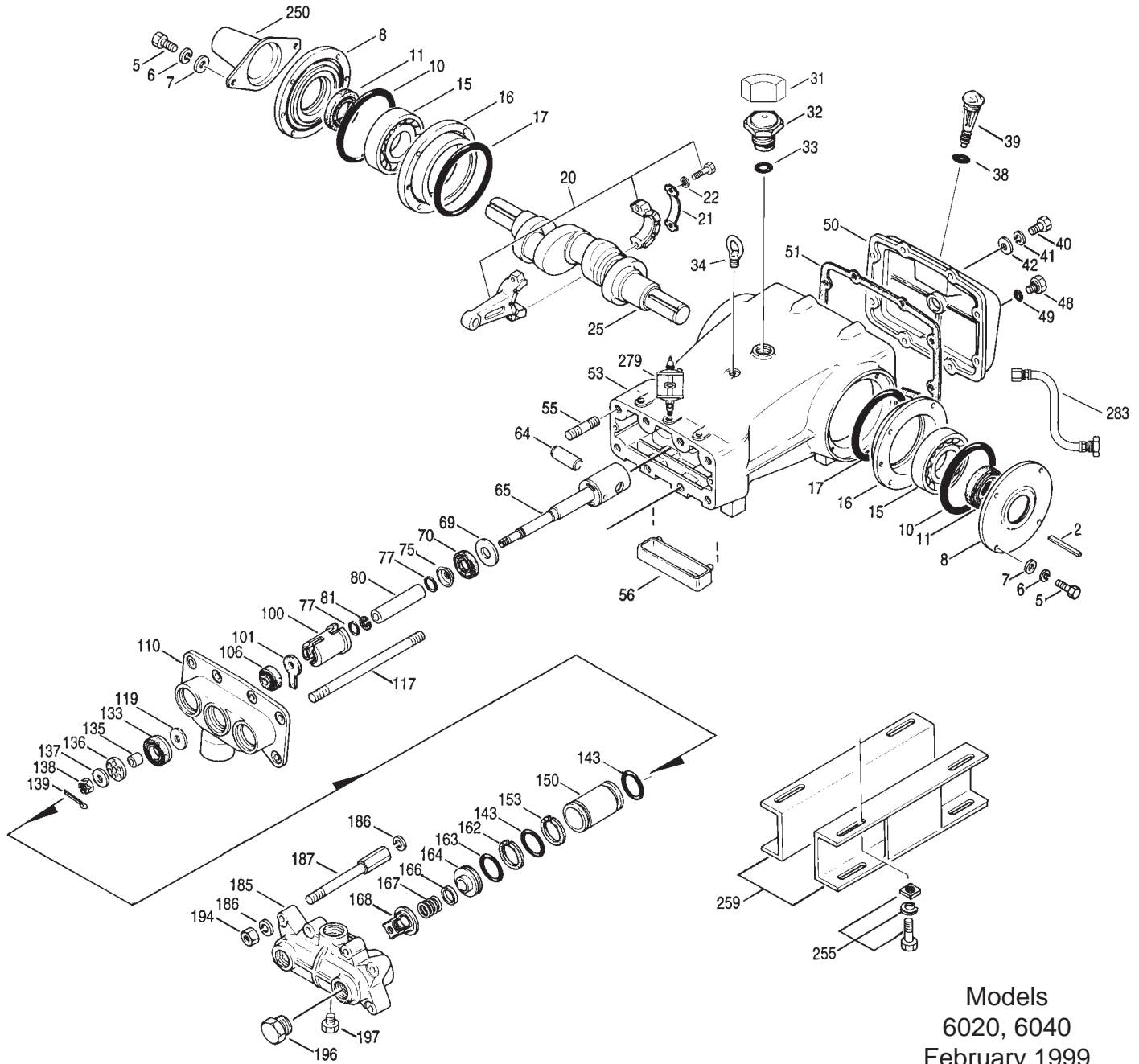

Models
6020, 6040
February 1999

	6020	MATL	6040	MATL		
● 250	29445	AL	29445	AL	Protector, Shaft (Included with Pump)	1 ●
● 255	33243		33243		Direct Mount (Included with Pump)	1 ●
● 259	29477	STZP	29477	STZP	Rail, Mounting (Included 2 with Pump)	2 ●
● 275	—		—		Hub & Key Assy [See complete Drive Packages, Tech Bulletin 03]	1 ●
● 279	30429	STZP	30429	STZP	Oilers (10 oz.)	3 ●
● 281	30969		30969		Oilers, Glass (10 oz.)	3 ●
● 282	10070		10070		Gasket, Oiler (10 oz.)	3
● 283	34334		34334		Kit, Oil Drain	1 ●
● 300	30440	NBR	30433	NBR	Kit, Cup (Incls: 133, 139, 143)	1
● 302	30439	NBR	—		Kit, Piston (Incls: 119, 133, 135, 136, 137, 138, 139, 143)	1
● 305	30485	NBR	30485	NBR	Kit, Sleeve & Seal (Incls: 75, 77, 80, 81, 101, 106, 139)	1
● 306	30484	NBR	30484	NBR	Kit, Seal (Incls: 101, 106, 139)	1
● 310	30441	S	30441	S	Kit, Valve (Incls: 143, 162, 163, 164, 166, 167)	1
● 390	—		—		C.A.T. (For R.O. or Industrial Applications)	1 ●
● 391	—		—		Adapters (2 per C.A.T.) (See Data Sheet for complete selection)	2 ●

● Industrial discount. **Bold print part numbers are unique to a particular pump model.** *Italics are optional items.*

See Tech Bulletins 03, 24, 36, 64 and 74 for additional information.

C.A.T. highly recommended for pressurized inlet, R.O. and Industrial applications.

MATERIAL CODES (Not Part of Part Number): ABS=ABS Plastic AL=Aluminum BB=Brass BBP=Brass/Chrome Plated FCM=Forged Chrome-moly
FPM=Fluorocarbon (Viton®) HS=High Strength NBR=Medium Nitrile (Buna-N) POP=Polypropylene PTFE=Polytetrafluoroethylene (Teflon®)
S=304SS SCP=304SS/Chrome Plated SS=316SS SSZZ=316SS/Zamak STCP=Steel/Chrome Plated STL=Steel STZP=Steel/Zinc Plated
TG=PTFE/Graphite Compound (GIT) TR=Roulon

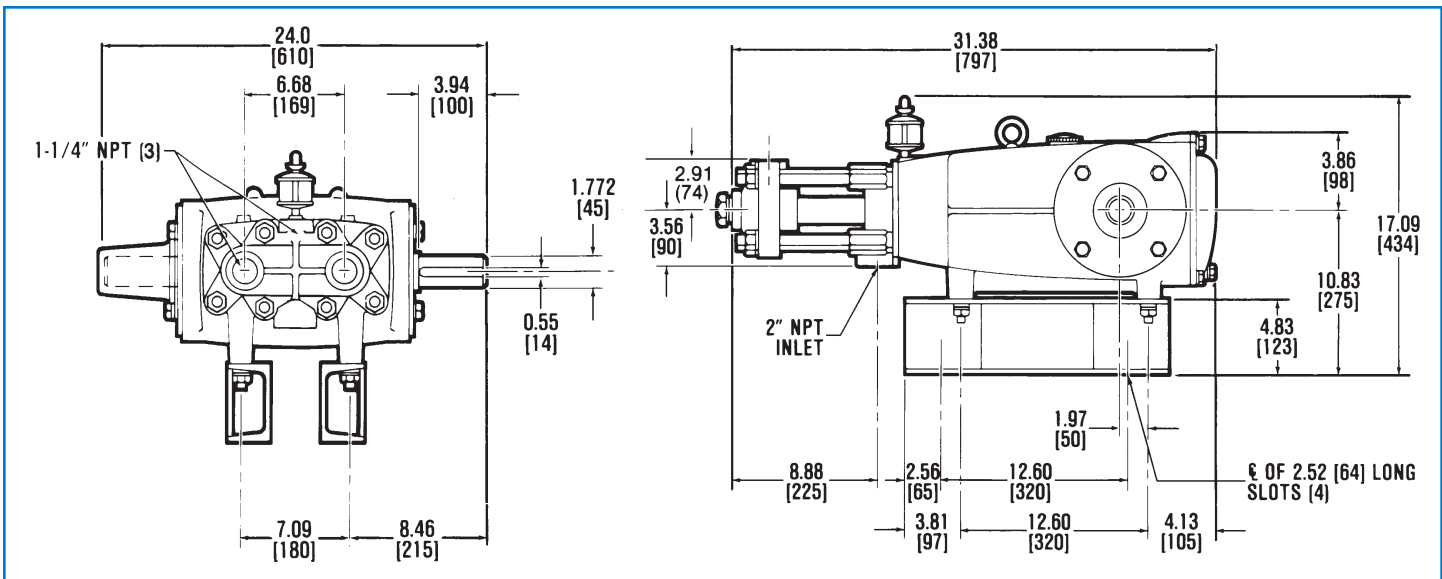

Models 6020, 6040

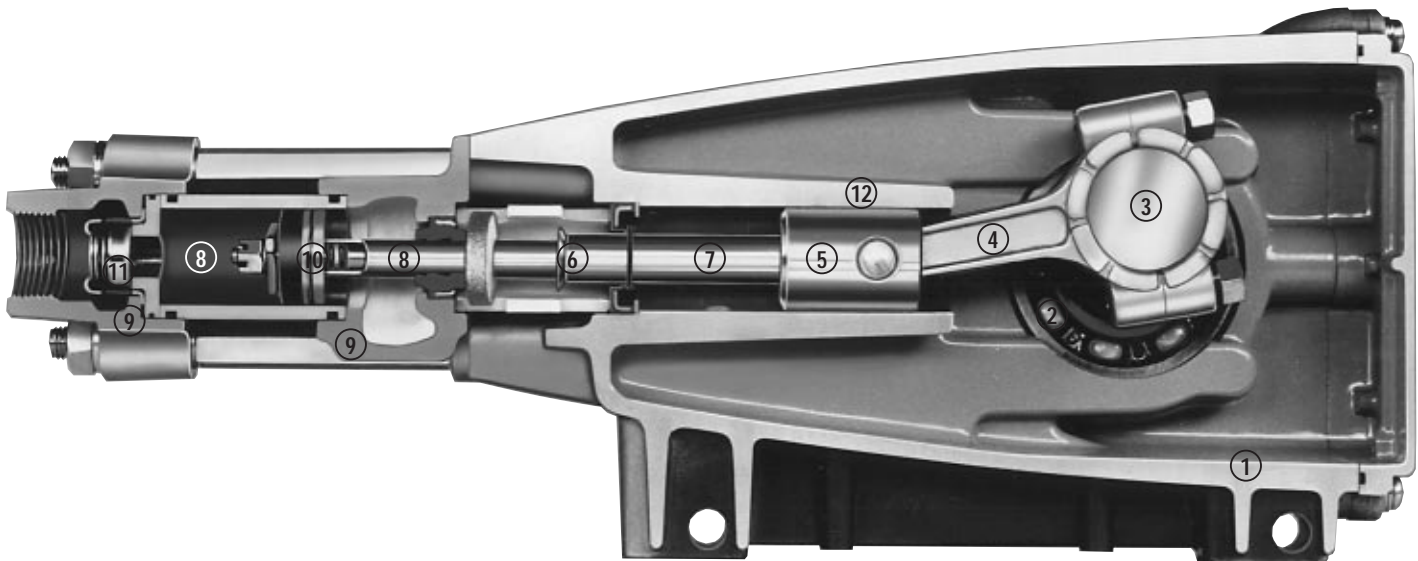

- 1 Die cast aluminum **crankcase** means high strength, lightweight, and excellent tolerance control.
- 2 Oversized crankshaft **bearings** provide extended bearing life and pump performance.
- 3 Chrome-moly **crankshaft** provides unmatched strength and surface hardness for long life.
- 4 Matched oversized high strength **connecting rods** are noted for superior strength and bearing quality.
- 5 The **piston rods** are high tensile strength 316 stainless steel with Zamak crossheads.
- 6 The stainless steel barrier **slinger** provides back-up protection for the crankcase seal, keeping pumped fluids out of the crankcase.
- 7 The **patented stepped piston rod** with hard chrome-plated stainless steel **sleeve** provides a durable wear surface and easy wet-end servicing.
- 8 The **cylinder and sleeve** wear surfaces are hard chrome-plated 304 stainless steel for longer service life.
- 9 **Manifolds** are of high tensile strength chrome-plated brass or 316 stainless steel for special corrosion resistance.
- 10 100% wet **cup/seal** design adds to service life by allowing pumped fluids to cool and lubricate the elastomers on both sides.
- 11 304 stainless steel **valves, seats, and springs** provide corrosion-resistance, positive seating and long life.
- 12 **Crossheads** are 360° supported for uncompromising alignment.

Products described hereon are covered by one or more of the following U.S. patents 3558244, 3652188, 3809508, 3920356, 3930756 and 5035580

Feb 1999 1938

World Headquarters

CAT PUMPS

1681 - 94th Lane N.E. Minneapolis, MN 55449-4324

Phone (612) 780-5440 — FAX (612) 780-2958

e-mail: sales@catpumps.com

www.catpumps.com

International Inquiries

FAX (612) 785-4443

e-mail: intlsales@catpumps.com



The Pump with "Nine Lives"

CAT PUMPS (U.K.) LTD.

1 Fleet Business Park, Sandy Lane, Church Crookham, Fleet

Hampshire GU13 0BF, England

Phone Fleet 44 1252-622031 — Fax 44 1252-626655

N.V. CAT PUMPS INTERNATIONAL S.A.

Heiveldekens 6A, 2550 Kontich, Belgium

Phone 32-3-450.71.50 — Fax 32-3-450.71.51

e-mail: cpi@catpumps.be

CAT PUMPS DEUTSCHLAND GmbH

Buchwiese 2, D-65510 Idstein, Germany

Phone 49 6126-93030 — Fax 49 6126-930333

e-mail: catpumps@t-online.de