



Proven Performance and Reliability

SRU Rotary Lobe Pump

PD 66342 GB1 2001-07

Application

The SRU range of rotary lobe pumps has been designed for use on wide ranging applications within the Brewing, Dairy, Food, Pharmaceutical and Chemical industries. The SRU pump can handle from low to high viscosity media and is suitable for CIP (Cleaning In Place) and conforms to USA 3A Sanitary Standard.

The characteristic smooth, low shear pumping action is ideal for products such as creams, gels, emulsions, aerated mixtures, and delicate cells and organic solids in suspension.

The SRU range is compact in size and highly efficient, capable of flow rates up to 106 m³/h and pressures up to 20 bar. The new improved modular design provides for greater application flexibility and cost effective easy maintenance.

Standard Design

Pump Gearbox

The SRU pump with its conventional lobe pump design concept has a robust cast iron gearbox, which provides maximum shaft rigidity and easy oil seal replacement. The SRU range in series 1-4 has a universal gearbox design. This gives the flexibility of mounting pumps with the inlet and outlet ports in either a vertical or horizontal plane by changing the foot position. The SRU range in series 5 & 6 has dedicated gearbox castings, which also allows the inlet and outlet ports to be in either the vertical or horizontal plane.

A quality epoxy paint system is used on the gearbox exterior for optimum protection against natural and corrosive elements.

Pumphead Construction

The SRU in standard specification has sanitary design full bore inlet and outlet ports to International Standards, maximising inlet and outlet port efficiency and NPSH characteristics. Enlarged diameter and rectangular ports are also available to handle very high viscosity products.

The SRU in standard specification has tri-lobe rotors with the option of bi-lobe rotors for handling fluids containing large delicate solids. All rotors are available in three temperature ratings allowing the pump to be operated at maximum process temperatures of 70°C, 130°C and 200°C for both fluid pumped and CIP.

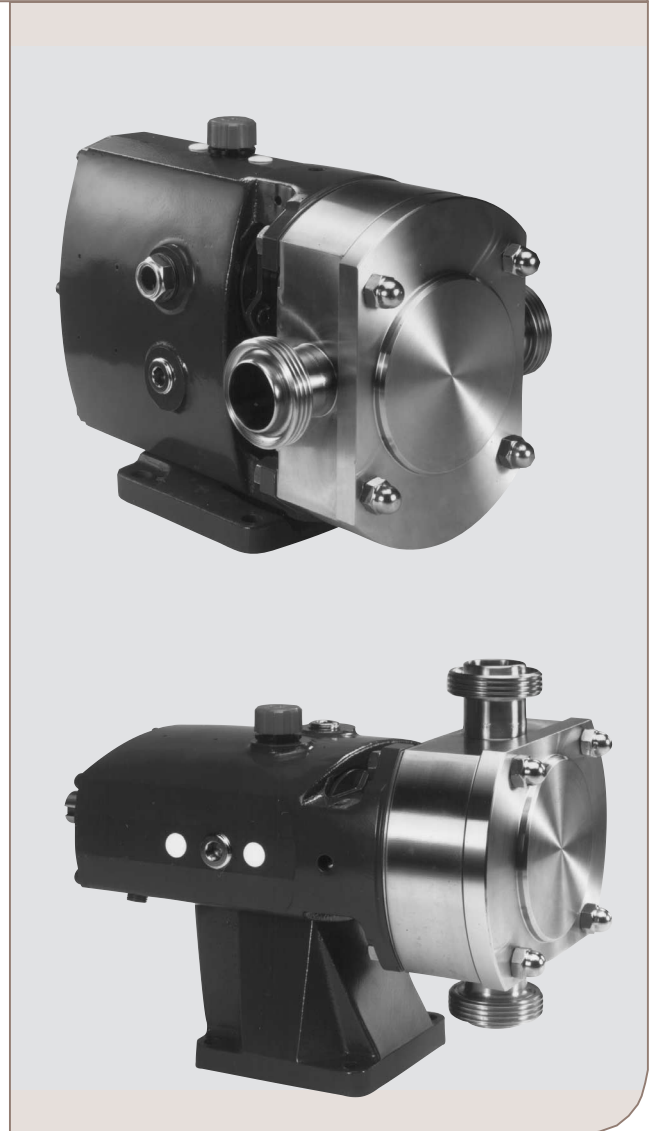

SRU Rotary Lobe Pump

Maximum Solid Size Capability

	Max. size of spherical solids (mm)	
	Bi-lobe rotors	Tri-lobe rotors
SRU1/005	8	6
SRU1/008	8	6
SRU2/013	8	6
SRU2/018	13	9
SRU3/027	13	9
SRU3/038	16	11
SRU4/055	16	11
SRU4/079	22	15
SRU5/116	22	15
SRU5/168	27	18
SRU6/260	27	18
SRU6/353	37	24

Materials of Construction

Pump gearbox – high quality grey cast iron.

Pumphead – product wetted components in 316L or equivalent stainless steel.

Product wetted elastomers of EPDM, NBR, FPM all FDA conforming. Also PTFE for chemical applications.

Weight

Model	Bare Shaft Pump (kg)	
	Horizontal porting	Vertical porting
SRU1/005	15	16
SRU1/008	17	18
SRU2/013	28	30
SRU2/018	29	31
SRU3/027	53	56
SRU3/038	56	59
SRU4/055	105	111
SRU4/079	110	116
SRU5/116	152	152
SRU5/168	160	160
SRU6/260	260	260
SRU6/353	265	265

Shaft Seal Options

- Single or single flush/quench (steam barrier for aseptic application) R90 or Hyclean type mechanical seals.
- Double R90 type mechanical seal for flush.
- Packed gland (unflushed or flushed versions).

Materials for Mechanical Seals

Carbon/Stainless steel, Tungsten Carbide/Tungsten Carbide, Silicon Carbide/Silicon Carbide or variations of these materials to suit fluid being pumped and/or application requirements. (N.B. Material variants are not available on all R90/Hyclean seal types)

Pump Sizing

In order to correctly size a rotary lobe pump some essential information is required. Provision of this information listed below enables our Customer Support personnel to obtain the optimum pump selection.

Product/Fluid Data

- Fluid to be pumped
- Viscosity
- SG/Density
- Pumping temperature, minimum, normal and maximum
- Cleaning in Place temperature(s), minimum, normal and maximum

Performance Data

- Flow rate, minimum, normal and maximum
- Discharge head/pressure (closest to pump outlet)
- Suction condition

Standard Specification Options

- Specification of inlet and outlet ports (Screwed male to BSP, DIN11851, Rdg, SMS, ISS/IDF, RJT, IAMD/3A, Tri-clamp and other standards, or Flanged to BS4504/DIN2533, ASA/ANSI 150, BS10E and other standards)
- Rotorcase Cover with integral Pressure Relief Valve
- Heating/Cooling Saddle Jackets for Rotorcase and Jacket for Rotorcase Cover (not available when relief valve fitted)
- Bi-lobe Rotors in stainless steel and non-galling alloy.
- Electropolished product wetted components
- Complete pump unit comprising: Pump + Baseplate (mild or stainless steel) + coupling with guard + Geared electric motor suitable for (or supplied with) frequency speed control or manual variable speed drive (advise motor enclosure and electrical supply).

Working Principle

The positive displacement of the SRU pump is provided by non-contacting, contra rotating tri-lobe or bi-lobe rotors within a fully swept pump chamber. All SRU pumps are capable of bi-rotational flow without modification.

Fig. 1

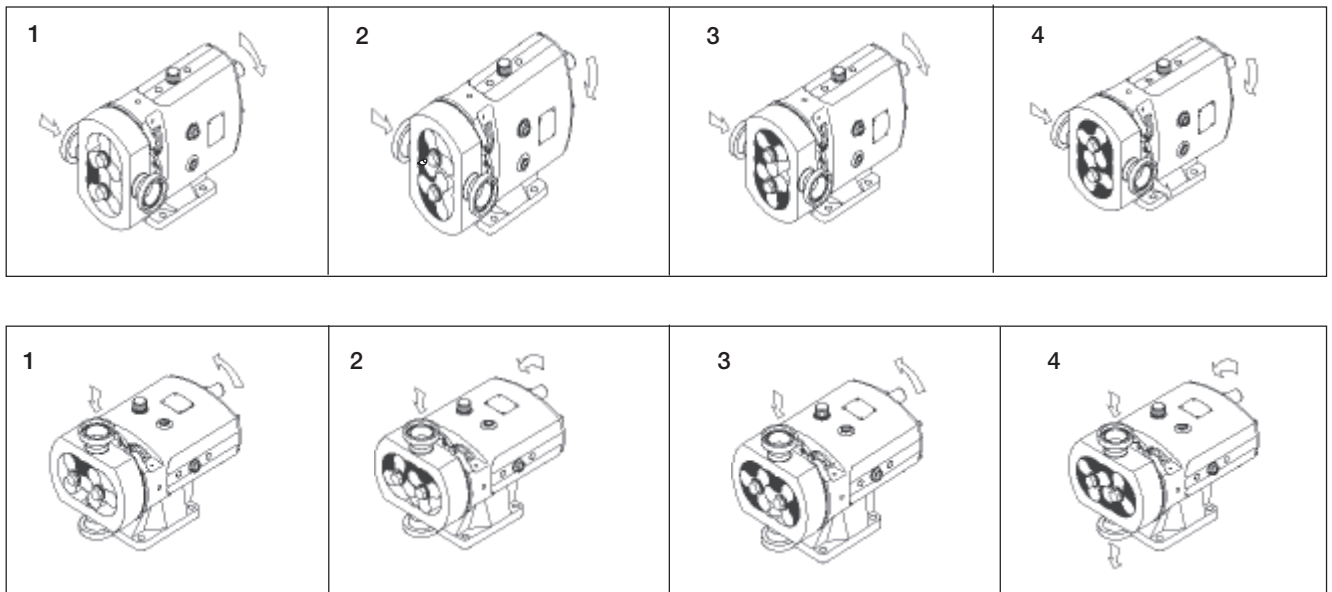

Flows/Pressures/Connections

SRU Series	Build Selection			SRU Model	Displacement			Inlet and Outlet Connection Size				Differential Pressure		Maximum Speed rev/min
	Pump head Code	Gearbox L - Horizontal Porting H - Vertical Porting	Shaft S - Stainless Steel D - Duplex Stainless Steel		Litres/ rev	Imp gall/ 100 rev	US gall/ 100 rev	Sanitary		Enlarged		bar	psi	
								mm	in	mm	in			
1	005	L or H	D	SRU1/005/LS or HD	0.053	1.17	1.4	25	1	-	-	8	115	1000
	008	L or H	D	SRU1/008/LS or HD	0.085	1.87	2.25	25	1	40	1.5	5	75	1000
2	013	L or H	S	SRU2/013/LS or HS	0.128	2.82	3.38	25	1	40	1.5	10	145	1000
	013	L or H	D	SRU2/013/LS or HD	0.128	2.82	3.38	25	1	40	1.5	15	215	1000
	018	L or H	S	SRU2/018/LS or HS	0.181	3.98	4.78	40	1.5	50	2	7	100	1000
	018	L or H	D	SRU2/018/LS or HD	0.181	3.98	4.78	40	1.5	50	2	10	145	1000
3	027	L or H	S	SRU3/027/LS or HS	0.266	5.85	7.03	40	1.5	50	2	10	145	1000
	027	L or H	D	SRU3/027/LS or HD	0.266	5.85	7.03	40	1.5	50	2	15	215	1000
	038	L or H	S	SRU3/038/LS or HS	0.384	8.45	10.15	50	2	65	2.5	7	100	1000
	038	L or H	D	SRU3/038/LS or HD	0.384	8.45	10.15	50	2	65	2.5	10	145	1000
4	055	L or H	S	SRU4/055/LS or HS	0.554	12.19	14.64	50	2	65	2.5	10	145	1000
	055	L or H	D	SRU4/055/LS or HD	0.554	12.19	14.64	50	2	65	2.5	20	290	1000
	079	L or H	S	SRU4/079/LS or HS	0.79	17.38	20.87	65	2.5	80	3	7	100	1000
	079	L or H	D	SRU4/079/LS or HD	0.79	17.38	20.87	65	2.5	80	3	15	215	1000
5	116	L or H	S	SRU5/116/LS or HS	1.16	25.52	30.65	65	2.5	80	3	10	145	600
	116	L or H	D	SRU5/116/LS or HD	1.16	25.52	30.65	65	2.5	80	3	20	290	600
	168	L or H	S	SRU5/168/LS or HS	1.68	36.95	44.39	80	3	100	4	7	100	600
	168	L or H	D	SRU5/168/LS or HD	1.68	36.95	44.39	80	3	100	4	15	215	600
6	260	L or H	S	SRU6/260/LS or HS	2.60	57.20	68.70	100	4	100	4	10	145	500
	260	L or H	D	SRU6/260/LS or HD	2.60	57.20	68.70	100	4	100	4	20	290	500
	353	L or H	S	SRU6/353/LS or HS	3.53	77.65	93.26	100	4	150	6	7	100	500
	353	L or H	D	SRU6/353/LS or HD	3.53	77.65	93.26	100	4	150	6	15	215	500

Note 1. These pressure ratings may vary for pumps with certain threaded connections.

Dimensions

Horizontally ported

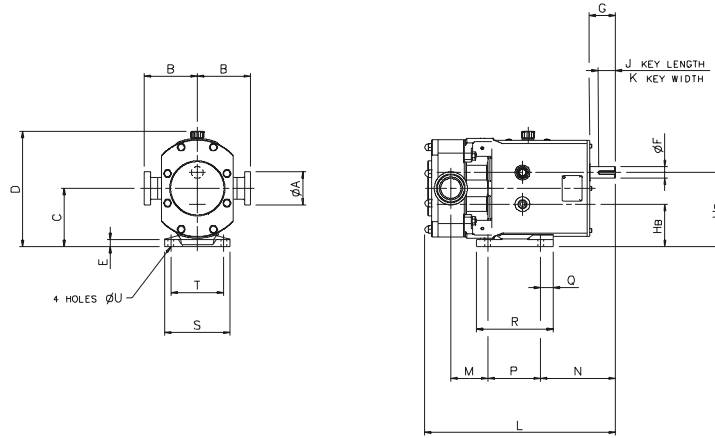

A1 denotes sanitary port dimension
 A2 denotes enlarged port dimension

M1 denotes standard port dimension for superseded range.
 M2 refers to enlarged or sanitary port.

All dimensions in mm

PUMP	A1	A2	B	C	D	E	F	G	HB	HT	J	K	L	M1	M2	N	P	Q	R	S	T	U
SRU1/005/L	25	-	95	90.5	189	10	16	40	68	113	30	5	285	46	42	124	80	10	100	100	80	10
SRU1/008/L	25	40	95	90.5	189	10	16	40	68	113	30	5	295	50.5	48	124	80	10	100	100	80	10
SRU2/013/L	25	40	105	115	233	15	22	50	85	145	32	6	339	63.5	60	131	100	19	132	124	100	12
SRU2/018/L	40	50	105	115	233	15	22	50	85	145	32	6	348	66.5	63	131	100	19	132	124	100	12
SRU3/027/L	40	50	125	137.5	273	18	28	61	100	175	40	8	437	86.5	82.5	176	125	30	181	154	125	14
SRU3/038/L	50	65	125	137.5	273	18	28	61	100	175	40	8	450	94.5	87	176	125	30	181	154	125	14
SRU4/055/L	50	65	150	163	325	20	38	80	115	211	63	10	541	109	101	224	150	35	202	184	150	14
SRU4/079/L	65	80	150	163	325	20	38	80	115	211	63	10	558	118	110	224	150	35	202	184	150	14
SRU5/116/L	65	80	175	195	376	20	45	110	135	255	70	14	627	106	97	279	180	35	275	210	180	14
SRU5/168/L	80	100	175	195	376	20	45	110	135	255	70	14	650	117	108	279	180	35	275	210	180	14
SRU6/260/L	100	100	190	225	429	20	48	110	155	295	70	14	748	134.5	124.5	266	260	40	370	220	190	14
SRU6/353/L	100	150	190	225	429	20	48	110	155	295	70	14	777	147	140	266	260	40	370	220	190	14

Vertically ported

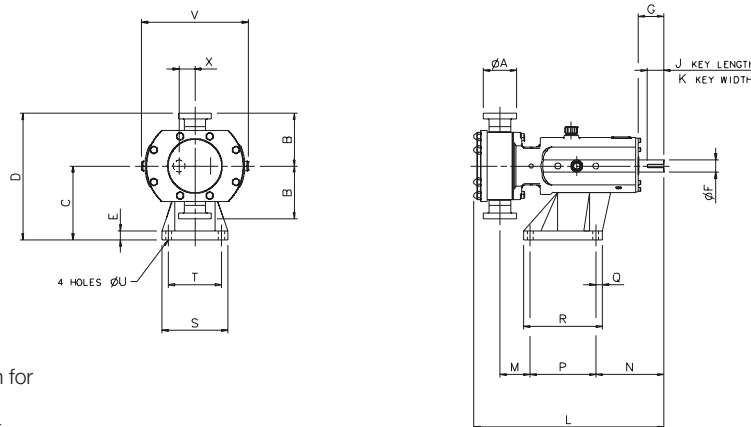

A1 denotes sanitary port dimension
 A2 denotes enlarged port dimension

M1 denotes standard port dimension for superseded range.
 M2 refers to enlarged or sanitary port.

All dimensions in mm

PUMP	A1	A2	B	C	D	E	F	G	J	K	L	M1	M2	N	P	Q	R	S	T	U	V	X
SRU1/005/H	25	-	95	113	208	15	16	40	30	5	285	53	49	117	80	22	114	104	80	10	179	22.5
SRU1/008/H	25	40	95	113	208	15	16	40	30	5	295	57.5	55	117	80	22	114	104	80	10	179	22.5
SRU2/013/H	25	40	105	147	252	15	22	50	32	6	339	70.5	67	124	100	12	124	124	100	12	219	30
SRU2/018/H	40	50	105	147	252	15	22	50	32	6	348	73.5	70	124	100	12	124	124	100	12	219	30
SRU3/027/H	40	50	125	175	300	22	28	61	40	8	437	71.5	67.5	161	155	15	185	155	125	14	253	37.5
SRU3/038/H	50	65	125	175	300	22	28	61	40	8	450	79.5	72	161	155	15	185	155	125	14	253	37.5
SRU4/055/H	50	65	150	213	363	25	38	80	63	10	541	86	78	197	200	17	234	184	150	14	307	48
SRU4/079/H	65	80	150	213	363	25	38	80	63	10	558	95	87	197	200	17	234	184	150	14	307	48
SRU5/116/H	65	80	175	256.5	431.5	30	45	110	70	14	627	100.5	91.5	264	200	20	240	220	180	14	345	60
SRU5/168/H	80	100	175	256.5	431.5	30	45	110	70	14	650	112	103	264	200	20	240	220	180	14	345	60
SRU6/260/H	100	100	190	295	485	30	48	110	70	14	748	134	124	267	260	20	300	250	210	14	400	70
SRU6/353/H	100	150	190	295	485	30	48	110	70	14	777	146	139	267	260	20	300	250	210	14	400	70

PD 66342 GB1 2001-07

The information contained herein is correct at the time of issue, but may be subject to change without prior notice.

How to contact Alfa Laval

Contact details for all countries are continually updated on our website. Please visit www.alfalaval.com to access the information direct.